

Modalities and Multimodalities

Domain
Definitions
Challenges

1

1

Domain and definitions

- Multimodal systems
 - Multi-Sensori-Motor Systems
 - extend the sensori-motor capabilities of computer systems

2

2

Domain and definitions

- Beyond the traditional User Interface (UI)
 - Windows: scroll, resize, move
 - Icons: representations, drag/drop
 - Menus: pop-up, pull-down
 - Pointers: mouse, digitizer, trackball, etc.
- Multimodal systems
 - Multi-modal refers to interfaces that support non-GUI interaction
 - Speech and gesture are two common examples and are complementary



3

Domain and definitions

"New Interfaces" extend the sensori-motor capabilities of computer systems

Multimodal \neq Multimedia

Multimodal \neq Speech interface

New interaction capabilities appear



4

Media - Modality

- Media
 - material (signal on a channel)
 - the support of communication
- Modality
 - a channel or path of communication between the human and the computer
 - sensorial (audition, vision, etc.)
 - of communicating/interacting (voice, gestures, facial expressions, etc.)
 - A modality is a process of receiving and producing chunks of information

5

5

Multimedia - Multimodality

- Multimedia system
 - transport signals of different kinds
 - For ex.: a sound clip attached to a presentation
- Multimodal system
 - interpret signs belonging to **various sensory and interaction modalities**
 - For ex.: the combined input of speech and gesture



6

6

Multimodal and crossmodal

- Multimodal interaction makes use of several input and/or feedback modalities in interacting with a computer system.
 - **Modality= human sensory channel, input interaction modality or output representation modality,**
 - Examples of modalities: manual gestures, gaze, touch, speech, head & body movements
- Crossmodal interaction makes use of a different human sensory modality to present information typically presented through another modality.

7

7

System: Input/Output modality

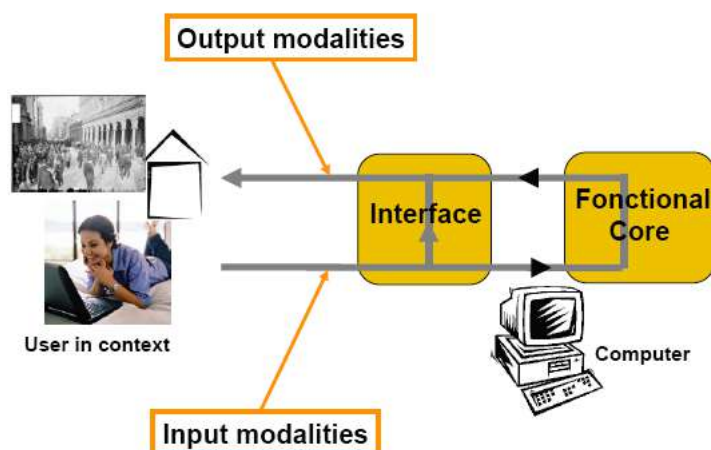

8

8

Multimodal interaction

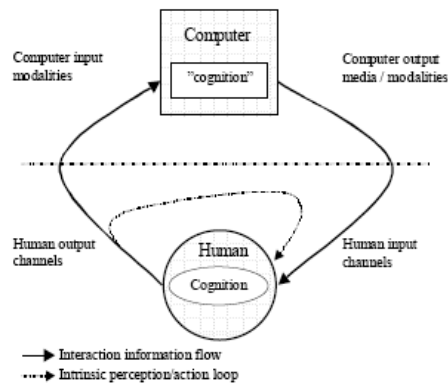

9

9

Human sensory channels / System output modalities

Sensory perception	Human sense Organ	Human input Modality
Sense of sight	Eyes	Visual
Sense of hearing	Ears	Auditive
Sense of touch	Skin	Tactual
Sense of smell	Nose	Olfactory
Sense of taste	Tongue	Gustatory
Sense of balance	Organ of equilibrium	Vestibular

- Tactual
 - Tactile: Cutaneous sensitivity
 - Kinaesthetic: Awareness of movement, orientation of limbs and position
 - Haptic: combination of tactile and kinaesthetic



<https://www.3dsystems.com/haptics-devices/touch>

10

10

MacGurk effect



11

MacGurk effect

- Voice ba ba ba
- Lips ga ga ga
- Result: combined percept
- There are strong individual differences in terms of what is perceived: da da



12

Human multisensory perception

- Sight and sound
 - there can be effects of our visual perception upon the way we interpret sound
 - McGurk effect

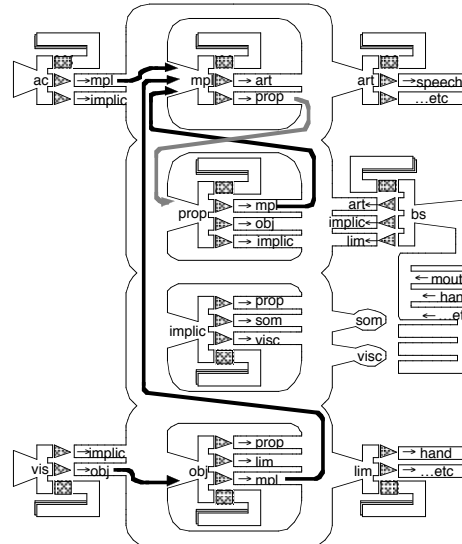

13

Human output systems / System input modalities

Human motor system muscle action controlling movement of limbs	System input device contact or non contact sensing
hands	keyboards, pen, mouse, trackpad, etc.
eye	eye tracker
facial expression	video camera
body movement	accelerometers, magnetometers, gyrometer, etc.
Speech Vocal utterance	microphone, speech recognition, topic recognition
Breath Pressure sensing for exhalation	Breath controllers, microphone
Bio-electric signals	EMG-signals relate to muscle activity EEG - brainwaves GSR - Galvanic skin response ECG - heart rate



14

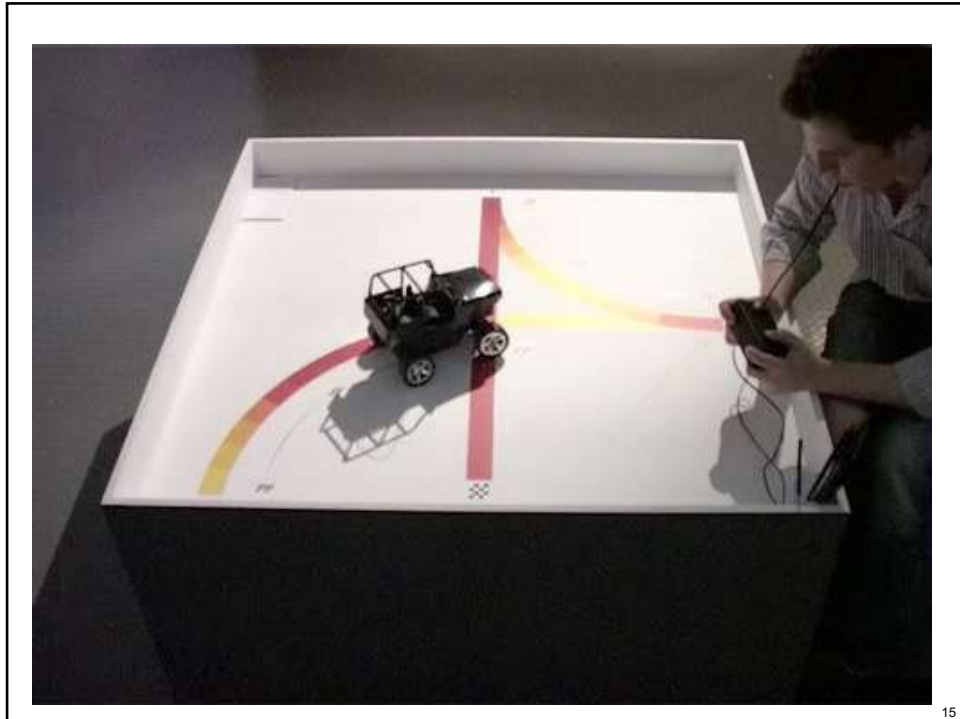

15

Multimodal (MM) versus GUI

- GUI interfaces often restrict input to single non-overlapping events, while MM interfaces handle all inputs at once
- GUI events are unambiguous, MM inputs can be based on recognition

16

Why multimodal?

- Most technologies are mature

- Gesture

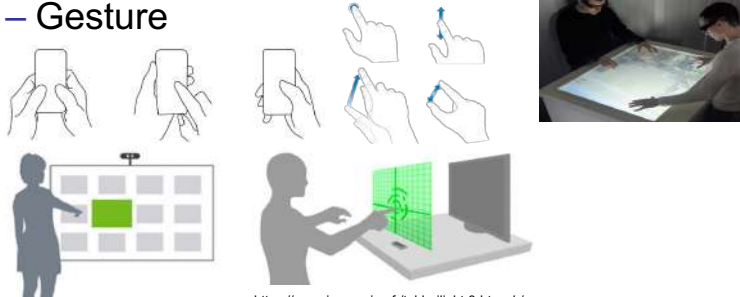

<https://www.immersion.fr/table-ilight-3d-touch/>
<https://www.invisionapp.com/inside-design/effective-gestural-interaction-design>
<https://www.clubic.com/technologies-d-avenir/article-575170-1-leap-motion-test.html>

- Speech



17

Why multimodal?

- Most technologies are mature

- Gesture

- Speech

- Seek to optimize the distribution of information over different modalities
- For adaptive, cooperative and flexible interaction among people

18

Why multimodal?

- Naturalness
 - provide more “natural” interfaces Usability
- Usability / flexibility
 - improve ease-of-use
- Robustness/Efficiency/Accuracy
 - decrease error rates (Mutual disambiguation of recognition errors)
- Perception
- Relieve burden on the visual channel
- Support users with disabilities

19

19

Why multimodal?

- Natural interaction is the long-term goal of being able to communicate with machines in the same ways in which humans communicate with one another
 - Input/output audiovisual speech, facial expression, gesture, gaze, body posture, physical action, touch, etc.
- **Natural interaction is multimodal by nature**



Language as a multimodal phenomenon Phil. Trans. R. Soc. B 2014 369 20130292; DOI: 10.1098/rstb.2013.0292.
Published 4 August 2014

20

20

Why multimodal?

- **Flexibility for Robutness**
 - Advantages for error recovery
 - Users intuitively pick the modality that is less error-prone
 - Language is often simplified
 - Users intuitively switch modality after an error, so that the same problem is not repeated
- **Flexibility to accommodating a wide range of users, tasks, and environments**
 - Users with disability (permanent or temporary)
 - Variable usage context (**mobile support, ubiquitous computing**)

21

21

Why multimodal?

- Because of the user's circumstances – including her task, her background, her training, her knowledge, and the context– the user may well have preferences as to how she interacts with the computer.



- A familiar example is that if the user is engaged in a task which occupies her hands, she may prefer to use speech.



- Another example: Suppose that the user wishes to book a flight from somewhere in Europe to Las Vegas. She may not know what is the nearest international airport, so she would prefer to indicate her destination by pointing on a map – or at the very least, by choosing from an appropriately filtered list of airports.

22

Why multimodal?

- What do these persons have in common?



23

23

Why multimodal?

- Enabling the user
- New multimodal technologies enable the user to be better engaged in the interaction, to receive more information through several modalities
- Multimodal interaction makes using of information technology possible for people with special needs, e.g., for blind and visually impaired people

24

24

Summary: Why multimodal?

- **Natural interaction**
 - Observation: Human-to-Human interaction is intrinsically multimodal
 - Motivation: Humans should be able to communicate with machines in the same ways they communicate with one another

25

25

Summary: Why multimodal?

- **Flexible interaction**
 - Observation: Humans optimize their information bandwidth with the environment switching between modalities or combining multiple modalities
 - Motivation: Robust efficient multimodal interaction
 - To accommodate users with different needs and preferences (e.g. disabilities, hands-busy)
 - To adapt to the context of use (**pro-active computing**)

26

26

Summary: Why multimodal?

- **Natural interaction**
 - Motivation: Humans should be able to communicate with machines in the same ways they communicate with one another
- **Flexible interaction**
 - Motivation: Robust efficient multimodal interaction
 - To accommodate users with different needs and preferences
 - To adapt to the context of use (**pro-active computing**)

27

27

Summary: Why multimodal?

- **Natural interaction** ①
 - Motivation: Humans should be able to communicate with machines in the same ways they communicate with one another
- **Flexible interaction** ②
 - Motivation: Robust efficient multimodal interaction
 - To accommodate users with different needs and preferences
 - To adapt to the context of use (**pro-active computing**)

③



Three paradigms for multimodality

28

28

Three paradigms for multimodality

- **Computer as partner** ①
 - The multiple modalities are used to increase the anthropomorphism of the user interface
- **Computer as tool** ②
 - Multiple input modalities are used to enhance direct manipulation
- **Proactive computing (ubicomp, PUI, ...)** ③
 - Multiple modalities are used to sense the context of use

29

29

Three paradigms for multimodality

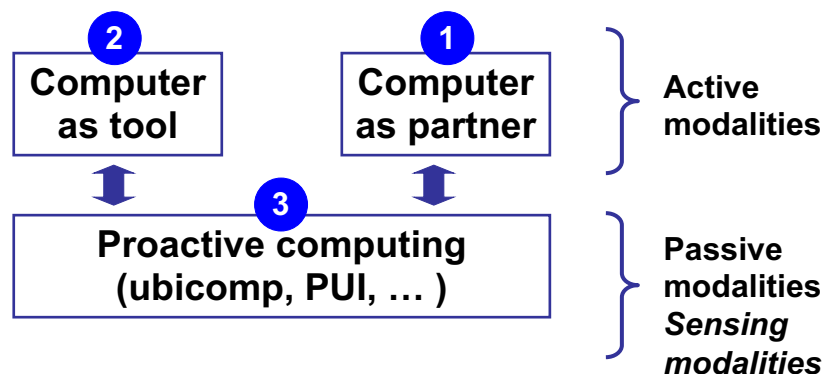

30

30

Three paradigms for multimodality

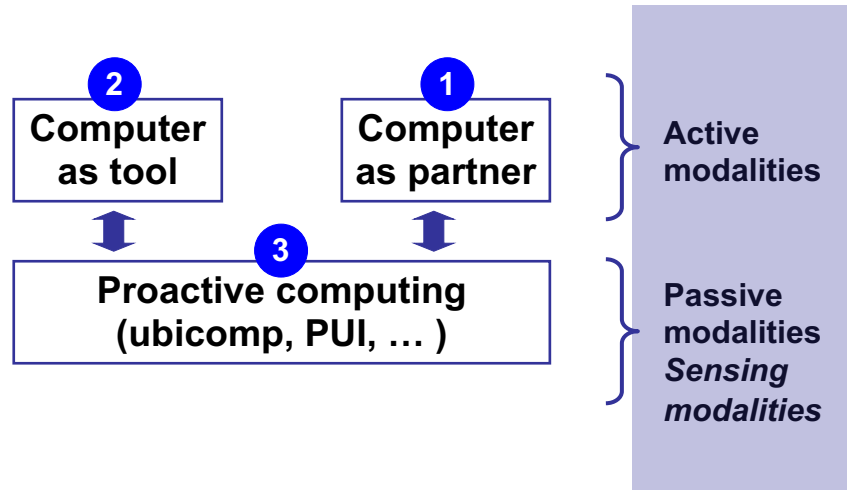

31

31

Passive/Active Modality

- **ACTIVE MODALITIES**
 - For inputs, active modalities are used by the user to issue a command to the computer
 - For example: a pedal to validate a selection in a CAS system.
- **PASSIVE - IMPLICIT MODALITIES**
 - Passive modalities are used to capture relevant information for enhancing the realization of the task, information that is not explicitly expressed by the user to the computer (PUI).
 - For example: eye tracking, tracking position.



32

Three paradigms for multimodality

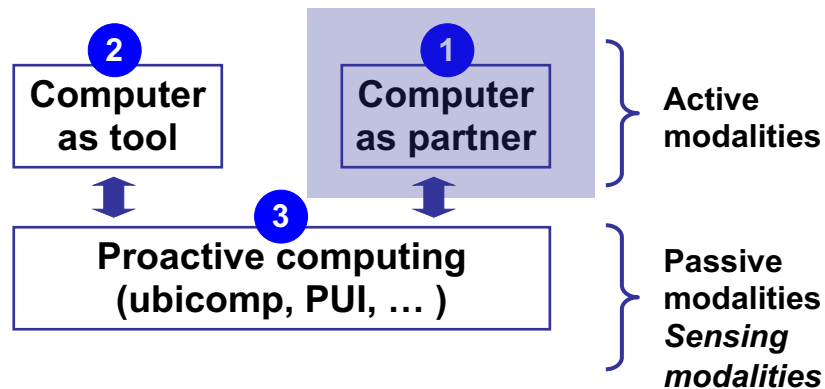

33

33

Computer as partner Multimodality

- The multiple modalities are used to increase the anthropomorphism of the user interface
 - agent based conversational user interfaces
 - multimodal output is important: talking heads and other humanlike presentation modalities
 - speech recognition is a common input modality in these systems, and speech synthesis is used as an output modality



34

34

Computer as partner Multimodality

- **Multimodal output** is important:
- talking heads and other humanlike presentation modalities

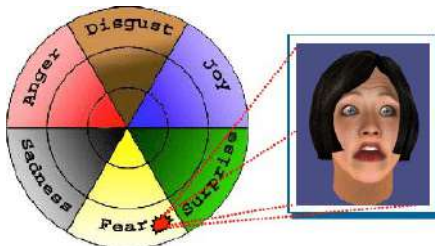

LUCIA: An Open Source 3D Expressive Avatar



NICO – Neuro-Inspired COmpanion:
A Developmental Humanoid Robot Platform for Multimodal Interaction
<http://nico.knowledge-technology.info>

35

35

Computer as partner Multimodality

- **Multimodal human-robot interaction**



NICO – Neuro-Inspired COmpanion:
A Developmental Humanoid Robot Platform
for Multimodal Interaction
<http://nico.knowledge-technology.info>

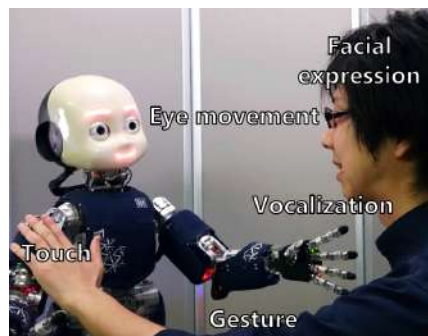

<https://doi.org/10.1145/3125739.3125757>

36

36

Three paradigms for multimodality

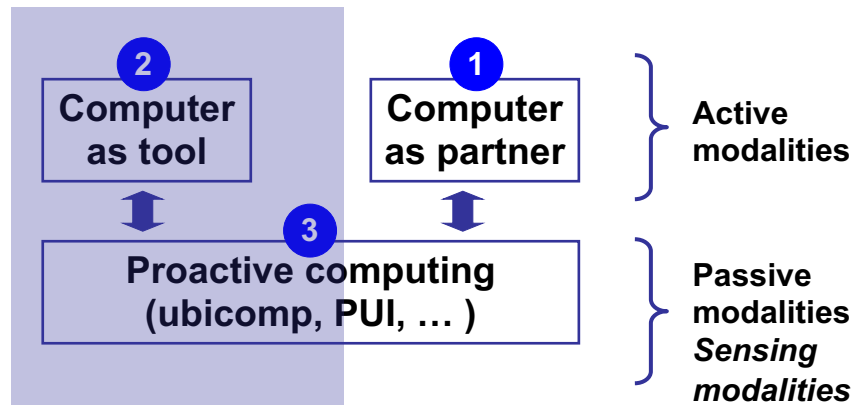

37

37

Computer as tool Multimodality

- The user is responsible for initiating the actions
- Multiple input/output modalities are used to enhance direct manipulation behavior of the system
 - Interaction modalities



38

38

Multimodality: Path to evolution

- Since 1980 “Put that there” paradigm
R. Bolt MIT

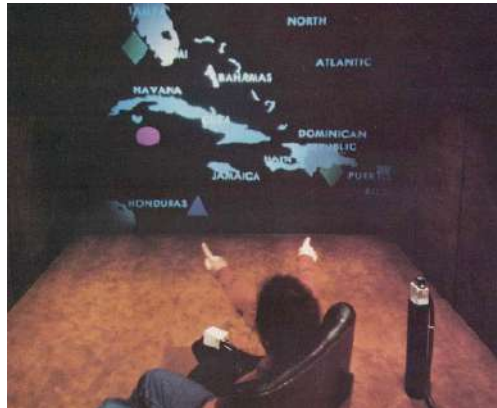

39

39



40

40

Multimodality: Path to evolution

- “Put that there” paradigm

„Zoom in here”

User selects a point of interest clicking with a stylus and speaking in order to focus it.



41

Multimodality: Path to evolution

- “Put that there” paradigm

„Play this sound logo”

User selects a sound logo by clicking on the title with a stylus and speaking in order to hear it



42

Multimodality: Path to evolution

- “Put that there” paradigm



43

43



44

44

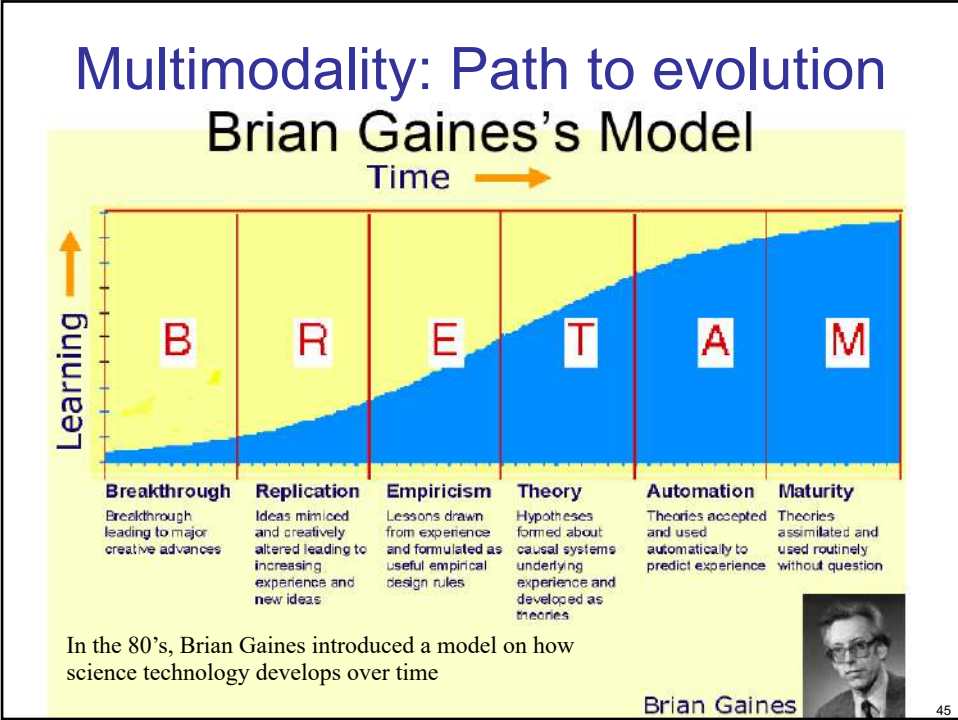

45

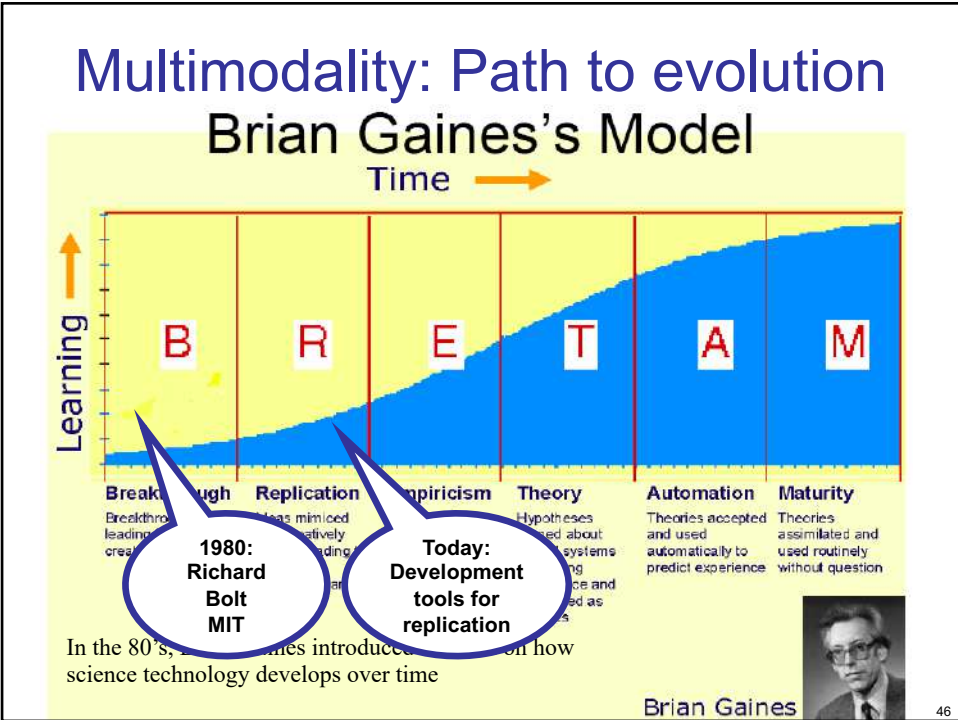

46

OpenInterface platform

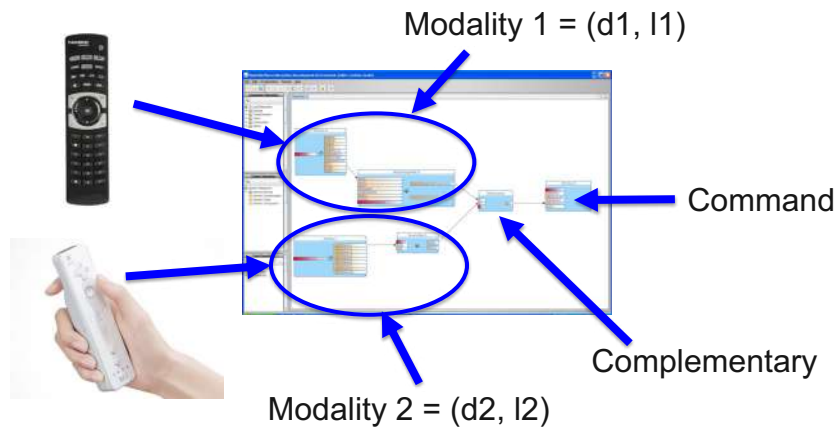

47

Components - Modalities

- 82 components including 30 devices



CubeTile (immersion)



Jack and Stone (University of Glasgow)

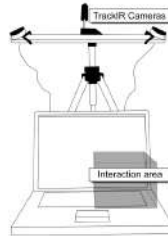

AirMouse (Laboratory of Grenoble)



48

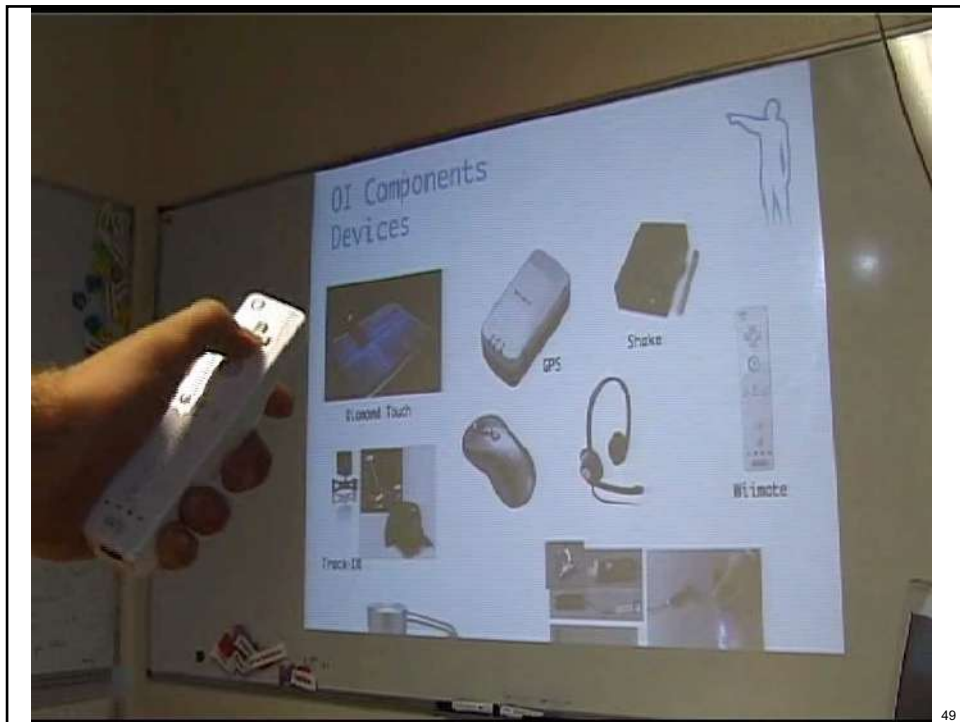

49

Readings

- Bolt, R. A. "Put-that-there": Voice and gesture at the graphics interface. Proceedings of SIGGRAPH'80, 14, 3 (1980), 262-270
- Martin, J. C. TYCOON: Theoretical Framework and Software Tools for Multimodal Interfaces. Intelligence and Multimodality in Multimedia Interfaces, AAAI Press (1997)
- Nigay, L., Coutaz, J. The CARE Properties and Their Impact on Software Design. Intelligence and Multimodality in Multimedia Interfaces, (1997)
<http://iihm.imag.fr/publs/1997/IMMI97-ChapterNigay.pdf>
- Oviatt, S. "Ten myths of multimodal Interaction", Comm. of the ACM, 42, 11 (1999), 74-81
- Turk, M., Robertson, G. Eds, Perceptual user Interfaces. Comm. of the ACM, 43, 3 (2000), 32-70

50

50

Readings

- **ACM SIGCHI: ACM's Special Interest Group on Computer-Human Interaction**
 - <http://www.sigchi.org/>
- **ICMI conference**
 - International Conference on Multimodal Interfaces
- **CHI conference**
 - Computer Human Interface
- **UIST conference**
 - User Interface Software and technology
- **MobileHCI conference**
 - Human Computer Interaction with Mobile Devices and Services

51

51